

N9.330 CR2

SPECIFICATIONS

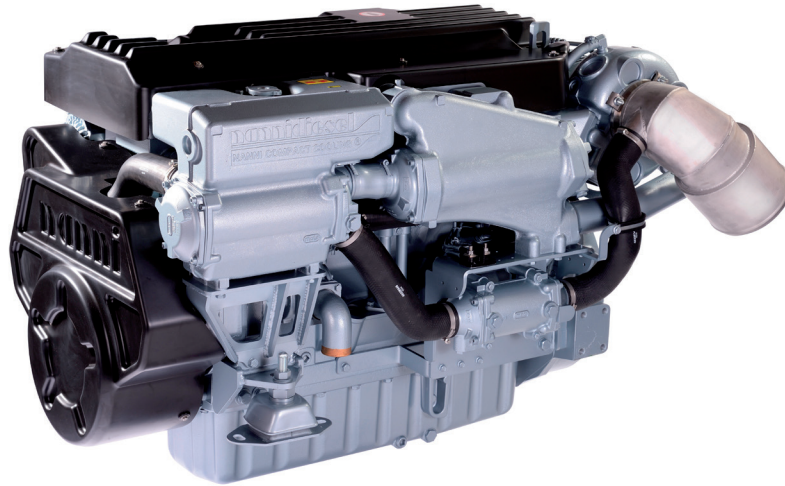

| | | | |
|---------------------|---------------------------------|---------------------|---|
| Power at crankshaft | 242 kW [329 cv] | Engine base | John Deere |
| Displacement | 9 l [549 in ³] | Fuel system | Direct injection High pressure Common Rail Electronically controlled |
| Configuration | 6 cylinders in line | Air intake | Turbocharged Air-to-seawater aftercooler |
| Operation type | 4 strokes Diesel | Cooling | Closed cooling with heat exchanger |
| Bore & Stroke | 118.4 x 136 mm [4.66 x 5.35 in] | Max mounting angle | 0° Front down 12° Front up |
| Compression ratio | 16.3 : 1 | Alternator | 24 Volt 100 Amp |
| Rated speed | 2100 rpm | Rating | M1 |
| Idling speed | 650 rpm | Emission compliance | IMO Marpol Annex VI NRMM (97/68/EC) Tier 3 EPA marine Tier 3 RCD2 2013/53/EU |
| Peak torque | 1444 Nm | Dry weight | 948 kg [2089 lbs] |
| Peak torque speed | 1600 rpm | | |

N9.330 CR2

242 kW [329 cv] at 2100 rpm

TECHNICAL DESCRIPTION

ENGINE BLOCK

- Replaceable wet-type cylinder liners
- 4 Valves per cylinder
- Watercooled exhaust manifold

FUEL SYSTEM

- Primary & secondary fuel filter
- Fuel heater
- Common Rail fuel injection system

LUBRICATION SYSTEM

- Replaceable full-flow oil filter
- Oil dipstick
- Oil cooler

COOLING SYSTEM

- Closed cooling with heat exchanger
- Gear driven self-priming raw water pump
- Coolant circulating pump
- Water cooled exhaust elbow

ELECTRICAL SYSTEM & INSTRUMENTATION

- 24V / 100A alternator
- 24V starter motor
- Complete instrumentation including key switch and alarms
- Extension cable harness with plug-and-play

AIR INTAKE

- Water cooled turbocharger
- Air-to-seawater aftercooler

OTHER FEATURES

- Flywheel SAE 2
- Flexible engine mounting
- Damper pulley

OPTIONAL SYSTEMS & ACCESSORIES

- Keel cooling adaptation
- Dry exhaust elbow
- Complete marine propulsion systems
- Marine transmission adaptation kits
- Throttle and shift controls
- Additional instrumentation, Flying bridge extension harness
- Rigid engine mounting
- Power take off
- Type approval

RATINGS

- 24 daily operating hours
- Load factor over 65%
- Uninterrupted full power

TRANSMISSIONS

- Contact your Nanni representative for more details and availability about transmissions types and models range.

PERFORMANCE CURVES

POWER AT CRANKSHAFT

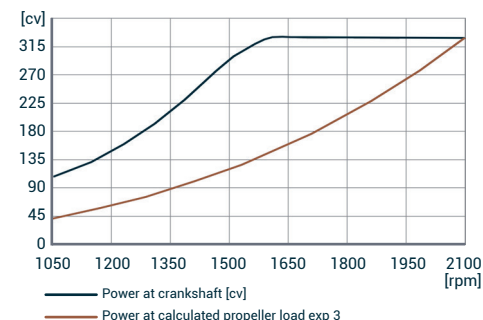

TORQUE AT CRANKSHAFT

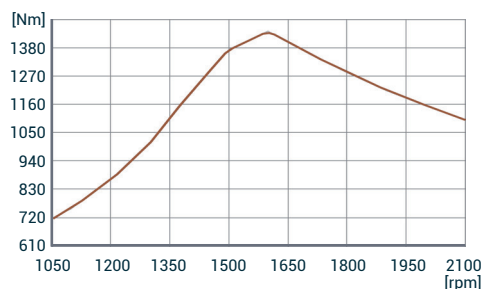

FUEL CONSUMPTION

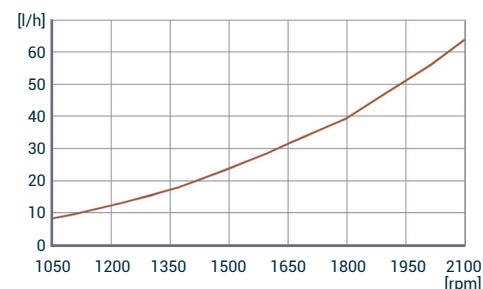

DIMENSIONS

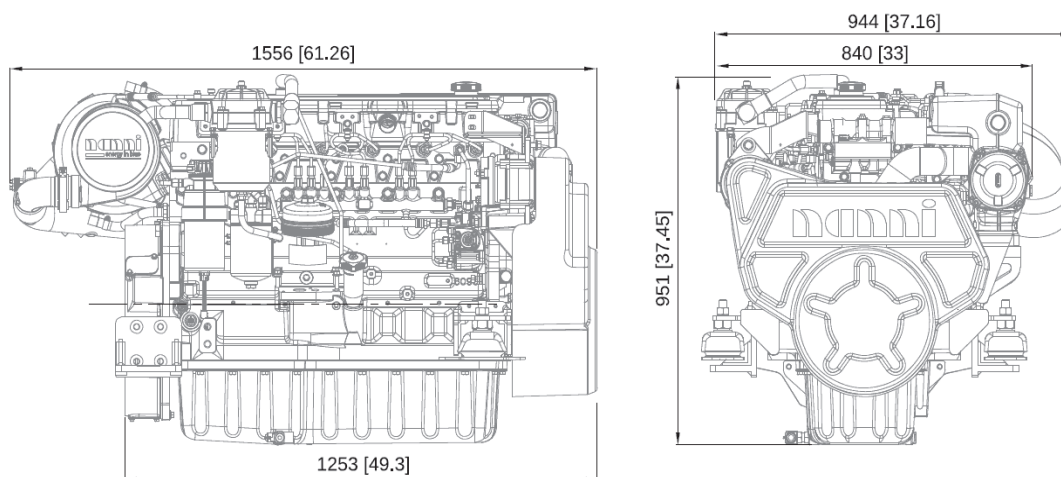

NANNI INDUSTRIES S.A.S.

11, Avenue Mariotte - Zone Industrielle
33260 La Teste - France
Tel: +33 (0)5 56 22 30 60
Fax: +33 (0)5 56 22 30 79

Technical data according to ISO 8665. This document is not contractual. Nanni reserves the right to modify any of the characteristics stated in this document without notice, in a constant effort to improve the quality of its products. Images and illustrations may show non standard equipments. All combination of equipment & accessory are not available.

DGBXXC01038