

N9.380 CR2

Specifications



Power at crankshaft	280 kW [381 hp]	Engine base	John Deere
Displacement	9 l [549 in ³]	Fuel system	Direct injection High pressure Common Rail electronically controlled
Configuration	6 cylinders in line	Air intake	Turbocharged Air-to-seawater aftercooler
Operation type	4 stroke Diesel	Cooling	Closed cooling with heat exchanger
Bore & Stroke	118.4 x 136 mm [4.66 x 5.35 in]	Max mounting angle	0° Front down 12° Front up
Compression ratio	16.3:1	Alternator	24 Volt 100 Amp
Rated speed	2200 rpm	Rating	M2
Idling speed	650 rpm	Emission compliance	MO Annex VI compliant EPA marine Tier 3 NRMM 97/68/EC RCD2 2013/53/EU
Peak torque	1572.8 Nm		
Peak torque speed	1700 rpm		
Dry weight	948 kg [2089 lbs]		

N9.380 CR2

280 kW [381 hp] at 2200 rpm

TECHNICAL DESCRIPTION

Engine block

- Replaceable wet-type cylinder liners
- 4 Valves per cylinder
- Watercooled exhaust manifold

Fuel system

- Primary & secondary fuel filter
- Fuel heater
- Common Rail fuel injection system

Lubrication system

- Replaceable full-flow oil filter
- Oil dipstick
- Oil cooler

Cooling system

- Closed cooling with heat exchanger
- Gear driven self-priming raw water pump
- Coolant circulating pump
- Water cooled exhaust elbow

Electrical system & Instrumentation

- 24 V / 100 A alternator
- 24 V starter motor
- Complete instrumentation including key switch and alarms
- Extension cable harness with plug-in connection

Air intake

- Water cooled turbocharger
- Air-to-seawater aftercooler

Other features

- Flywheel SAE 2
- Flexible engine mounting
- Damper pulley

Optional systems & accessories

- Keel cooling adaptation
- Dry exhaust elbow
- Complete marine propulsion systems
- Marine transmission adaptation kits
- Throttle and shift controls
- Additional instrumentation, Flying bridge extension harness
- Rigid engine mounting
- Power take off
- Type approval

RATINGS

- Up to 5000 annual operating hours
- Load factor up to 65%
- Full power for no more than 16 hours out of each 24 hours of operation. The remaining operation time must be at or below cruising speed.

TRANSMISSIONS

- Contact your Nanni representative for more details and availability about transmissions types and models range

PERFORMANCE CURVES

Power at crankshaft

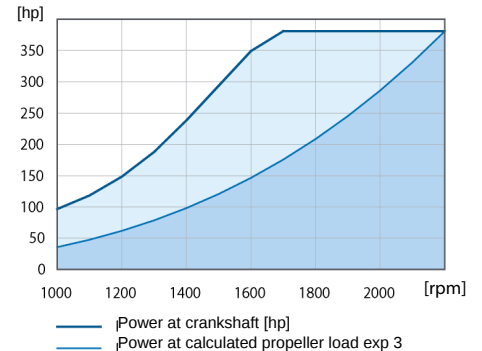

Fuel consumption

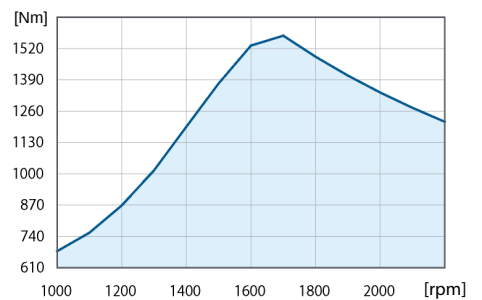

Torque at crankshaft

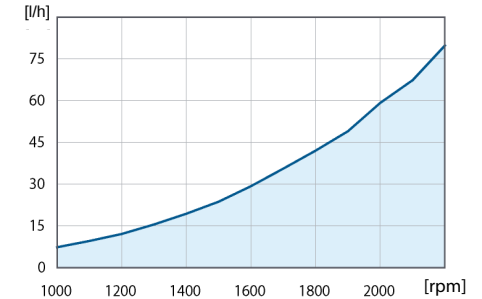

DIMENSIONS BOBTAIL

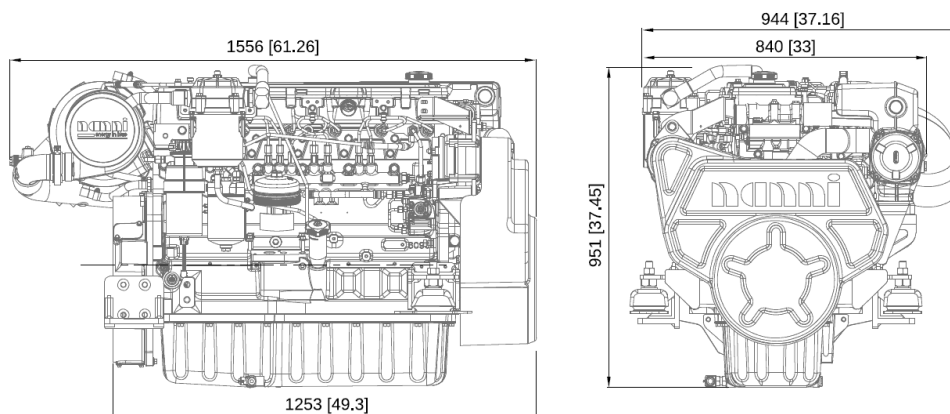

Nanni Industries S.A.S. France

11, Avenue Mariotte - Zone Industrielle
33260 La Teste - France
Tel: +33 (0)5 56 22 30 60
Fax: +33 (0)5 56 22 30 79

Nanni Trading S.R.L

Via Degli Olmetti, 5/B
00060 Formello (RM) - Italia
Tel: +39 06 30 88 42 51/52/53
Fax: +39 06 30 88 42 54

Technical data according to ISO 8665. Specifications are subject to change without notice. Images and illustrations may show non standard equipments. All combination of equipment & accessory are not available.

07-2017-ENG